

**PROJECT CASE STUDY**  
Packaged SMIP Smart  
Connector  
for Ectron Computers

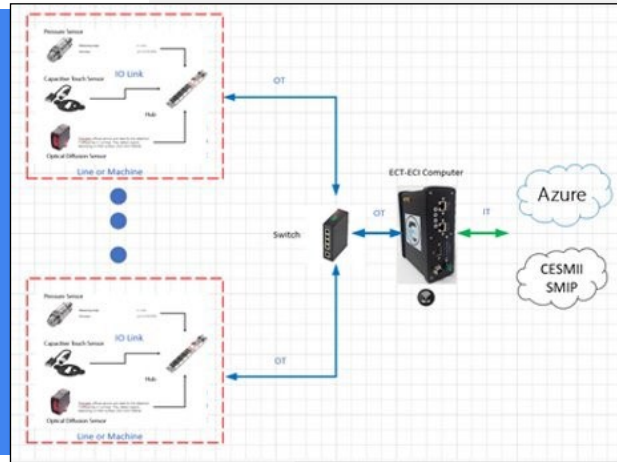

**PROJECT LEAD**

Ectron

**PROJECT TEAM**

None

**PROJECT OBJECTIVE**

Implement a generic oven profile for the Smart Manufacturing Innovation Platform. The profile will be implemented using ethernet IP on the Operational Technology (OT) side through the smart connector and OPC/UA (Open Platform Communications/Unified Architecture) on the Informational Technology (IT) side.

[MORE ON CESMII.ORG](https://www.cesmii.org)

## Information Modeling Boosts Productivity for Electronics Manufacturers

**BENEFITS TO OUR NATION**

The plug and play nature of the Ectron SmartEYE™ implementation puts automation, Factory 4.0, and the IIoT within the reach of small manufacturers who don't have IT and engineering teams.

Small and medium sized manufacturers (SMMs) will be able to access and implement technologies that were previously only available to large manufacturing enterprises. Since small and medium sized manufacturers comprise 98% of America's industrial manufacturing base, technologies available to SMMs will greatly benefit the nation as a whole.

**BENEFITS TO INDUSTRY**

- **Improved Energy Productivity**  
Availability of the generic oven profile will facilitate the creation of models for future use in CESMII Smart Manufacturing Innovation Platform projects involving industrial ovens. Specifically, these types of asset profiles incorporate energy usage and energy efficiency.
- **Improved Operational Efficiency**  
A critical piece of the electronics manufacturing process is burn-in and curing ovens. The profiles developed in this project will enable electronics manufacturers to increase efficiency by gauging, measuring and controlling energy usage during manufacturing processes involving ovens. These tools can also be extended beyond electronics to any industries using ovens, such as food and beverage, automotive, aerospace and others.

# PROJECT DESCRIPTION

## TECHNICAL APPROACH

- Develop a general-purpose oven profile for the Smart Manufacturing Innovation Platform.
- Develop a smart connector that connects edge computing devices to the Smart Manufacturing Innovation Platform.

## ACCOMPLISHMENTS

- Improved Ectron electronics production quality by implementing smart sensors and process controls.
- Improved productivity by reducing oven curing time.
- Improved energy efficiency by using smart sensors and controls to optimize oven temperature settings.
- Developed a generic Oven Profile for the CESMII Smart Manufacturing Innovation Platform that can be customized for industrial oven applications.
- Developed of a generic connector that uses Message Queuing Telemetry Transport (MQTT) to connect to the CESMII Smart Manufacturing Innovation Platform in a plug and play fashion.

## DELIVERABLES

- Completed integration of equipment sensors to Azure via SmartEYE. (SmartEYE is an IIoT-based Platform as a Service that provides a 360-degree view of factory operations.)
- Completed integration of equipment sensors to Smart Manufacturing Innovation Platform via SmartEYE.
- Developed generic oven profile.
- Implement a smart packaged connector to translate EthernetIP to the Smart Manufacturing Innovation Platform using OPC-UA.

## REUSABLE OUTCOMES / SM MARKETPLACE

- Generic oven SM profile.
- Smart connector to link edge devices to Smart Manufacturing Innovation Platform.
- Edge device that combines sensor integration, edge computing and a gateway to cloud based analytics.

# RESULTS

## \$120k/yr

Potential to increase revenue at Ectron plant by \$120k annually by improved productivity from implementing smart sensors and controls.

## 8%↓

Potential to reduce energy costs by 8% annually at Ectron plant by implementing smart manufacturing tools.

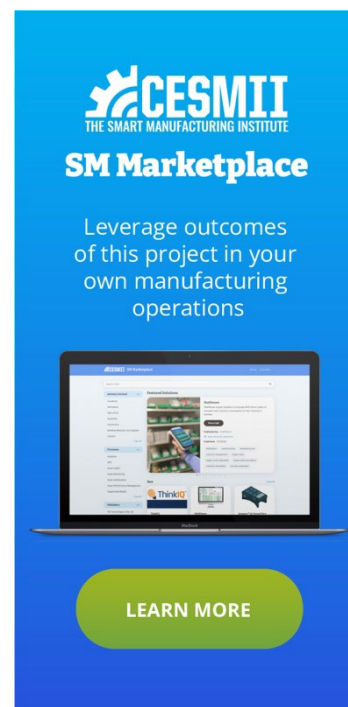

The banner features the CESMII logo (The Smart Manufacturing Institute) and the text 'SM Marketplace'. Below this, it says 'Leverage outcomes of this project in your own manufacturing operations'. An image of a laptop displaying a dashboard is shown. At the bottom, there is a green button with the text 'LEARN MORE'.

## PROJECT DETAIL

Budget Period: BP4/BP5  
Submission Date: 2/27/2022  
Sub-Award (contract) Number:  
4550 G YA223  
SOPO: 2328

## FOR MORE INFORMATION CONTACT

Name: Gautam Kavipurapu  
Position: VP Engineering  
Phone: (858)278-0600  
Email: [gkavipurapu@ectron.com](mailto:gkavipurapu@ectron.com)